

Black Hole

This game was invented by Ilze Rukis. It is a discrimination game, and tests the handler's ability to direct the dog to the correct obstacle.

Black Hole starts and ends at the table; no performance is required other than the dog has to have all 4 paws on the table to stop time. The handler will direct the dog through the numbered course to earn points. Points are accumulated for each correctly performed obstacle. The dog continues to earn points unless he/she goes into a pipe tunnel (the Black Hole). At that point scoring stops and the handler must direct the dog to the table to stop time. You will have 45 seconds to complete the course; the timer will blow the whistle at 45 seconds and you must then direct the dog to the table to stop time.

Scoring

Black Hole is scored points plus bonus, then time. Time is a tie-breaker only. Points are awarded as follows –

Jumps = 1 point

Tire = 3 points

Contact obstacles and weave poles = 5 points

Bonus – A 10 point bonus is awarded if the team finishes the course in less than 40 seconds.

Faulted obstacles (dropped bars, missed contacts) will earn no points. Wrong courses are not faulted (except into a tunnel). Errors in the weave poles are not faulted, but they must be performed correctly to earn points.

Qualifying

Games I – 26 points

Games II – 31 points

Games III – 41 points

Scribe Briefing













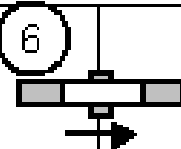

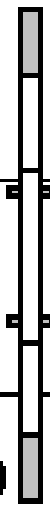



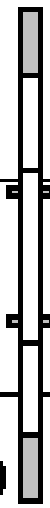

I will call out points (1, 3, 5) for each obstacle completed correctly. If a dog faults an obstacle, I will not say anything. If a dog enters a tunnel, I will call "fault", and the team will no longer accumulate any points.

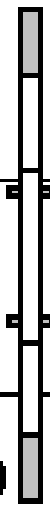
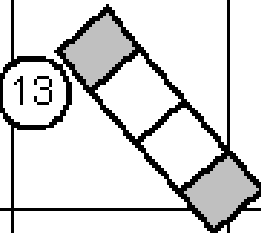
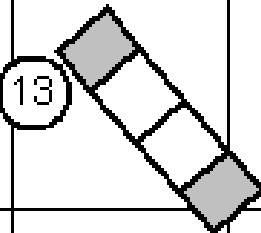
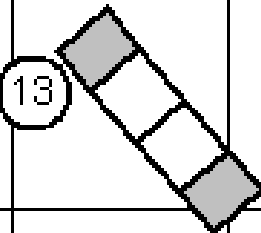
Timer Briefing

Start the stop watch when the dog leaves the table. If the dog takes a tunnel, the handler will need to direct the dog to the table to stop time. Stop timing when the dog has all four paws on the table. If the dog completes the course before the end of course time (45 seconds) record the time on the scribe sheet. Blow the whistle at 45 seconds.

Scorekeeping Table

The scribe sheets will show all points accumulated 1, 3, or 5). Add all of the points to get the total number of points. If the time recorded is under 40 seconds add 10 bonus points to the score. Record the time for tie breaking purposes only.

Little Rock ARFF
 Black Hole
 Marsha Nix
 Feb. 16, 2008